

RTXM290-701

-
- ***Direct LC receptacle optical interface***
 - ***Single +3.3V power supply***
 - ***Hot-pluggable***
 - ***Operating optical data rate up to 112Gbps***
 - ***Operating electrical serial data rate up to 28Gbps***
 -

- **Compliant with IEEE 802.3ba**
- **Compliant with CFP4 MSA hardware specification, Version 0.1 March 02, 2014**
- **Compliant with CFP MSA management specification, Version 2.2 July 01, 2013**
- **Compliant with ITU-T G.959.1 4I1-9D1F**
- **Compliant with RoHS&WEEE**

Storage Temperature Range	Ts	°C	-40	+85
Relative Humidity	RH	%	5	85
Power Supply Voltage	Vcc	V	-0.5	+3.6
Operating Case Temperature Range	Tc	°C	-5	75
Receiver Damage Threshold Per Lane	P _{dag}	dBm	+5.5	

Operating Case Temperature Range	Tc	°C	0	70	
Power Supply Voltage	Vcc	V	3.2	3.3	3.4
Data rate	Gb/s		103.125	112	

(tested under recommended operating conditions, unless otherwise noted)

Voltage Supply Electrical Characteristics							
Supply Current	Tx Section	I _{cc}	A	-	-	1.8	1
	Rx Section						
Power Supply Noise		V _{rip}				2%	DC-1MHz
						3%	1-10MHz
Dissipation	Class5	P _w	W			6	
Low Power Dissipation		P _{low}	W			2	
Inrush Current	Class5	I _{-inrush} mA/usec				200	
Turn-off Current		I _{-turnoff} mA/usec		-200			
Different Signal Electrical Characteristics							
Single Ended Data Input Swing		mV	55		-		

Input High Voltage	1.2VIH	V	0.84	1.5
Input Low Voltage	1.2VIL	V	-0.3	0.36
Input Leakage Current	1.2IIN	uA	-100	+100
Output High Voltage				

OMA for Each Lane
Los Assert

dBm

13	GLB_ALRMn	Global Alarm	I	3.3V LVCMOS	Ok	Alarm	
18	MDIO	Management Data Input Output Bi-Directional Data	I/O	1.2V LVCMOS			
17	MDC	MDIO Clock	I	1.2V LVCMOS			
19	PRTADR0	MDIO Physical Port address bit0	I	1.2V LVCMOS	per MDIO document[5]		
20	PRTADR1	MDIO Physical Port address bit1	I	1.2V LVCMOS			
21	PRTADR2	MDIO Physical Port address bit2	I	1.2V LVCMOS			

Timing Parameters for CFP hardware Signal Pins are listed in the following table.

Timing Parameters for CFP hardware Signal Pins

Parameter	Symbol	Min	Ma x	Uni t	Notes&Conditions
Hardware assert	MOD_LOPWR t_MOD_LOPWR_assert		1	ms	Application Specific May depend on current state Condition when signal is applied .See Vendor Datasheet
Hardware deassert	MOD_LOPWR t_MOD_LOPWR_deassert			ms	Value is dependent upon module start-up time.Please See register"Maximu m High-Power-up ime"in "CFP MSA Management Interface Specification"
Receiver Loss of Signal Assert Time	t_loss_assert		100	us	Maximum value designed to support telecom applications
Receiver Loss of Signal De-Assert Time	t_loss_deassert		100	us	Maximum value designed to support telecom applications
Global Alarm Assert Delay Time	GLB_ALRMn_assert		150	ms	This is a logical "OR" of Associated MDIO alarm& status registers.Please see MDIO document for further details
Global Alarm De-assert	GLB_ALRMn_deassert		150	ms	This is a logical

Delay Time					"OR" of Associated MDIO alarm& status registers. Please see MDIO document for further details
Management Interface Clock Period	t_prd	250		ns	MDC is 4MHz rate
Host MDIO t_setup	t_setup	10		ns	
Host MDIO t_hold	t_hold	10		ns	

Optional Transmitter and Receiver Monitor Clock Characteristics

		Min	Typ	Max	Unit	Notes
Impedance	Zd	80	100	120	Ω	
Frequency					MHz	1/8 of Network lane rate
Output Differential Voltage	V _{DIFF}	400		1200	mV	Peak to Peak Differential
Clock Duty Cycle		40		60	%	

CFP Register Allocation

Starting Address in Hex	Ending Address in Hex	Access Type	Allocated Size	Data Bit Width	Table Name and Description
0000	7FFF	N/A	32768	N/A	Reserved for IEEE 802.3 use
8000	807F	RO	128	8	CFP NVR 1. Basic ID register
8080	80FF	RO	128	8	CFP NVR 2. Extended ID register
8100	817F	RO	128	8	CFP NVR 3. Network lane specific registers
8180	81FF	RO	128	8	CFP NVR 4
8200	83FF	RO	4x128	N/A	MSA Reserved
8400	847F	RO	128	8	Vendor NVR 1. Vendor data registers
8480	84FF	RO	128	8	Vendor NVR 2. Vendor data registers
8500	87FF	RO	6x128	N/A	Reserved by CFP MSA
8800	887F	R/W	128	8	User NVR 1. User data registers
8880	88FF	R/W	128	8	User NVR 2. User data registers
8900	8EFF	RO	12x128	N/A	Reserved by CFP MSA
8F00	8FFF	N/A	2x128	N/A	Reserved for User private use
9000	9FFF	RO	4096	N/A	Reserved for vendor private use
A000	A07F	R/W	128	16	CFP Module VR1. CFP Module level control and DDM registers

A080

CFP NVR1

Hex Addr	Size	Access Type	Bit	Register Name	Content (HEX)	LSB Unit
Base ID Information						
8000	1	RO	7~0	Module Identifier	12	N/A
8001	1	RO	7~0	Extended Identifier	E4	N/A
8002	1	RO	7~0	Connector Type Code	07	N/A
8003	1	RO	7~0	Ethernet Application Code	01	N/A
8004	1	RO	7~0	Fiber Channel Application Code	00	N/A
8005	1	RO	7~0	Copper Link Application Code	00	N/A
8006	1	RO	7~0	SONET/SDH Application Code	00	N/A
8007	1	RO	7~0	OTN Application Code	08	N/A
8008	1	RO	7~0	Additional Capable Rates Supported	18	N/A
8009	1	RO	7~0	Number of Lanes Supported	44	N/A
800A	1	RO	7~0	Media Properties	11	N/A
800B	1	RO	7~0	Maximum Network Lane Bit Rate	8C	0.2Gbps
800C	1	RO	7~0	Maximum host Lane Bit Rate	38	0.2Gbps
800D	1	RO	7~0	Maximum Single Mode Optical Fiber Length	0A	km
800E	1	RO	7~0	Maximum Multi-Mode Mode Optical Fiber Length	00	10m
800F	1	RO	7~0	Maximum Copper Cable length	00	1m
8010	1	RO	7~0	Transmitter Spectral Characteristics1	00	N/A
8011	1	RO	7~0	Transmitter Spectral Characteristics2	04	N/A
8012	2	RO	7~0	Minimum Wavelength per Active Fiber		25pm
8014	2	RO	7~0	Maximum Wavelength per Active Fibe		25pm
8016	2	RO	7~0	Maximum per Lane Optical Width		1pm
8018	1	RO	7~0	Device Technology1		
8019	1	RO	7~0	Device Technology2		
801A	1	RO	7~0	Signal Code		
801B	1	RO	7~0	Maximum Total Optical Output Power per Connector		
801C	1	RO	7~0	Maximum Optical Input Power per Network Lane		
801D	1	RO	7~0	Maximum Power Consumption		
801E	1	RO	7~0	Maximum Power Consumption in Low Power Mode		
801F	1	RO	7~0	Maximum Operating Case Temp Range		
8020	1	RO	7~0	Minimum Operating Case Temp Range		
8021	16	RO	7~0	Vendor Name		
8031	3	RO	7~0	Vendor OUI		
8034	16	RO	7~0	Vendor Part Number		

				Number		
8069	1	RO	7~0	CFP MSA Management Interface Specification Revision Number		
806A	2	RO	7~0	Module Hardware Version Number		
806C	2	RO	7~0	Module Firmware Version Number		
806E	1	RO	7~0	Digital Diagnostic Monitoring Type		
806F	1	RO	7~0	Digital Diagnostic Monitoring Capability 1		
8070	1	RO	7~0	Digital Diagnostic Monitoring Capability 2		
8071	1	RO	7~0	Module Enhanced Options		
8072	1	RO	7~0	Maximum High-Power-up Time		
8073	1	RO	7~0	Maximum TX-Turn-on Time		

809A	2	RO	7~0	Auxiliary 1 Monitor High Warning Threshold		
809C	2	RO	7~0	Auxiliary 1 Monitor Low Warning Threshold		
809E	2	RO	7~0	Auxiliary 1 Monitor Low Alarm Threshold		
80A0	2	RO	7~0	Auxiliary 2 Monitor High Alarm Threshold		
80A2	2	RO	7~0	Auxiliary 2 Monitor High Warning Threshold		
80A4	2	RO	7~0	Auxiliary 2 Monitor Low Warning Threshold		
80A6	2	RO	7~0	Auxiliary 2 Monitor Low Alarm Threshold		
80A8	2	RO	7~0	Laser Bias Current High Alarm Threshold		
80AA	2	RO	7~0	Laser Bias Current High Warning Threshold		

				0~15		
--	--	--	--	------	--	--

Hex Addr	Size	Access Type	Bit	Register Name	Content (HEX)	LSB Unit
Base ID Information						
8180	1	RO	7~0	CFP NVR3 Checksum		
8181	127	RO	7~1	Reserved		

Hex Addr	Size	Access Type	Bit	Register Name	Content (HEX)	LSB Unit
Module Command/Setup Registers						
A000	2	RO	15~0	Reserved		
A002	2	RO	15~0	Reserved		
A004	1	RO				
			8~6	Reserved		
			4	Reserved		
		3~2	Command Status			
		RW	15~9	Reserved		
			5	User Restore and Save Command		
1~0	Extended Commands					
A005	1	RO				
			15~8	Reserved		
A006	1	RO				
			15~8	Reserved		
A007	1	RO				
			15~8	Reserved		
A008	1	RO				
			15~8	Reserved		
A009	1	RO				
			15~8	Reserved		
A00A	1	RO				
			15~8	Reserved		
A00B	1	RO		Module Bi-/Uni-Directional Operating Mode Select		
			15~3	Reserved		
A00C	4	RO		Module Bi/uni-Direction Mode Select		
			2~0	Reserved		
Module Control Registers						
A010	1					
		RW/SC/LH	15	Soft Module Reset		
		RW	14	Soft Module Low Power		
		RW	13	Soft TX Disable		
		RW	12	Soft PRG_CNTL3 Control		

	RW	11	Soft PRG_CNTL2 Control		
	RW	10	Soft PRG_CNTL1 Control		
	RW	9	Soft GLB_ALARM Test		
	RO	8~6	Reserved		
	RO	5	TX_DIS Pin State		
	RO	4	MOD_LOPWR Pin State		
	RO	3	PRG_CNTL3 Pin State		
	RO	2	PRG_CNTL2 Pin State		
	RO	1	PRG_CNTL1 Pin State		
	RO	0	Reserved		
1					
	RO	15	Reserved		
	RW	14	TX PRBS Generator Enable		
	RW	13	TX PRBS Pattern 1		
	RW	12	TX PRBS Pattern 0		
	RW	11	TX De-skew Enable		
	RW	10	TX FIFO Reset		
	RW	9	TX FIFO Auto Reset		
	RW	8	TX Reset		
	RW	7~5	TX MCLK Control		
	RO	4	Reserved		
	RW	3~1	TX Rate Select (10G lane rate)		

RW

				Summary		
			6	Lane 6 Alarm and Warning Summary		
			5	Lane 5 Alarm and Warning Summary		
			4	Lane 4 Alarm and Warning Summary		
			3	Lane 3 Alarm and Warning Summary		
			2	Lane 2 Alarm and Warning Summary		
			1	Lane 1 Alarm and Warning Summary		
			0	Lane 0 Alarm and Warning Summary		
A01A	1	RO				
			15	Lane 15 Fault and Status Summary		
			14	Lane 14 Fault and Status Summary		
			13	Lane 13 Fault and Status Summary		
			12	Lane 12 Fault and Status Summary		
			11	Lane 11 Fault and Status Summary		
			10	Lane 10 Fault and Status Summary		
			9	Lane 9 Fault and Status Summary		
			8	Lane 8 Fault and Status Summary		
			7	Lane 7 Fault and Status Summary		
			6	Lane 6 Fault and Status		

				Summary		
			9	Lane 9 Fault and Status Summary		
			8	Lane 8 Fault and Status Summary		
			7	Lane 7 Fault and Status Summary		
			6	Lane 6 Fault and Status Summary		
			5	Lane 5 Fault and Status Summary		
			4	Lane 4 Fault and Status Summary		
			3	Lane 3 Fault and Status Summary		
			2	Lane 2 Fault and Status Summary		

			1	Mod SOA Bias Low Warning		
			0	Mod SOA Bias Low Alarm		
A020	1	RO				
			15~8	Reserved		
			7	Mod Aux 1 High Alarm		
			6	Mod Aux 1 High Warning		
			5	Mod Aux 1 Low Warning		
			4	Mod Aux 1 Low Alarm		
			3	Mod Aux 2 High Alarm		
			2	Mod Aux 2 High Warning		
			1	Mod Aux 2 Low Warning		
			0	Mod Aux 2 Low Alarm		
A021	1	RO		Reserved		
A022	1					
		RO	15~9	Reserved		
		RO/LH/COR	8	High-Power-down State Latch		
		RO/LH/COR	7	High-Power-down State Latch		

2014-09-05 10:58:05 Page 216

		RO/LH/COR	4	Mod Vcc Low Alarm Latch		
		RO/LH/COR	3	Mod SOA Bias High Alarm Latch		
		RO/LH/COR	2	Mod SOA Bias High Warning Latch		
		RO/LH/COR	1	Mod SOA Bias Low Warning Latch		
		RO/LH/COR	0	Mod SOA Bias Low Alarm Latch		

A026 1

A02B	1	RO	0	Reserved		
		RO		Module Alarm and Warnings 1 Enable		
			15~12	Reserved		
			11	Mod Temp Hi Alarm Enable		
			10	Mod Temp Hi Warn Enable		
		9	Mod Temp Low Warning Enable			
			8	Mod Temp Low Alarm Enable		
			7	Mod Vcc High Alarm Enable		
			6	Mod Vcc High Warning Enable		
			5	Mod Vcc Low Warning Enable		
			4	Mod Vcc Low Alarm Enable		
			3	Mod SOA Bias High Alarm Enable		
			2	Mod SOA Bias High Warning Enable		
			1	Mod SOA Bias Low Warning Enable		
			0	Mod SOA Bias Low Alarm Enable		
A02C	1					
		RO	15~8	Reserved		
		RW	7	Mod Aux 1 High Alarm Enable		
			6	Mod Aux 1 High Warning Enable		
			5	Mod Aux 1 Low Warning Enable		
			4	Mod Aux 1 Low Alarm Enable		
			3	Mod Aux 2 High Alarm Enable		
			2	Mod Aux 2 High Warning Enable		
			1	Mod Aux 2 Low Warning Enable		
0	Mod Aux 2 Low Alarm Enable					
A02D	2	RO		Reserved		
Module Analog A/D Value Registers						
A02F	1	RO	15~0	Module Temp Monitor A/D Value		
A030	1	RO	15~0	Module Power supply 3.3 V Monitor A/D Value		
A031	1	RO	15~0	SOA Bias Current A/D Value		
A032	1	RO	15~0	Module Auxiliary 1 Monitor A/D Value		
A033	1	RO	15~0	Module Auxiliary 2 Monitor A/D Value		
A034	4	RO		Reserved		
Module PRBS Registers						
A038	1	RO				
			15~10	Exponent		
			9~0	Mantissa		
A039	1	RO				
			15~10	Exponent		
			9~0	Mantissa		
A03A	70	RO		Reserved		

Network Lane VR1						
Hex Addr	Size	Access Type	Bit	Register Name	Content (HEX)	LSB Unit
A200	16	RO				
			15	Bias High Alarm		
			14	Bias High Warning		
			13	Bias Low Warning		
			12	Bias Low Alarm		
			11	TX Power High Alarm		
			10	TX Power High Warning		
			9	TX Power Low Warning		
			8	TX Power Low Alarm		
			7	Laser Temperature High Alarm		
			6	Laser Temperature High Warning		
			5	Laser Temperature Low Warning		
			4	Laser Temperature Low Alarm		
			3	RX Power High Alarm		
			2	RX Power High Warning		
			1	RX Power Low Warning		
0	RX Power Low Alarm					
A210	16	RO				
			15	Lane TEC Fault		
			14	Lane Wavelength Unlocked Fault		
			13	Lane APU igerf33.9q 27(t)2		

				Alarm Latch		
			6	Laser Temperature High Warning Latch		
			5	Laser Temperature Low Warning Latch		
			4	Laser Temperature Low Alarm Latch		
			3	RX Power High Alarm Latch		
			2	RX Power High Warning Latch		
			1	RX Power Low Warning Latch		
			0	RX Power Low Alarm Latch		
A230	16	RO/LH/COR		Network Lane n Fault and Status latch		
			15	Lane TEC Fault Latch		
			14	Lane Wavelength Unlocked Fault Latch		
			13	Lane APD Power Supply		

		RW	14	Lane Wavelength Unlocked Fault Enable		
		RW	13	Lane APD Power Supply Fault Enable		
		RO	12~8	Reserved		
		RW	7	Lane TX_LOSF Enable		
		RW	6	Lane TX_LOL Enable		
		RO	5	Reserved		
		RW	4	Lane RX_LOS Enable		
		RW	3	Lane RX_LOL Enable		
		RW	2	Lane RX_FIFO Status Enable		
		RO	1~0	Reserved		
A260	32	RO		Reserved		

Network Lane VR1						
Hex Addr	Size	Access Type	Bit	Register Name	Content (HEX)	LSB Unit
A280	16					

A410	16					
		RO	15~2			

52	TX2n	5	3.3V	52	TX1n
51	TX2p	6	3.3V	51	TX1p
50	GND	7	3.3V_GND	50	GND
49	TX1n	8	3.3V_GND	49	TX2n
48	TX1p	9	VND_IO_A	48	TX2p
47	GND	10	VND_IO_B	47	GND
46	TX0n	11	TX_DIS(PRG_CNTL1)	46	TX3n
45	TX0p	12	RX_LOS(PRG_ALRM1)	45	TX3p
44	GND	13	GLB_ALRMn	44	GND
43	REFCLKn	14	MOD_LOPWR	43	REFCLKn
42	REFCLKp	15	MOD_ABS	42	REFCLKp
41	GND	16	MOD_RSTn	41	GND
40	RX3n	17	MDC	40	RX3n
39	RX3p	18	MDIO	39	RX3p
38	GND	19	PRTADR0	38	GND
37	RX2n	20	PRTADR1	37	RX2n
36	RX2p	21	PRTADR2	36	RX2p
35	GND	22	VND_IO_C	35	GND
34	RX1n	23	VND_IO_D	34	RX1n
33	RX1p	24	VND_IO_E	33	RX1p
32	GND	25	GND	32	GND
31	RX0n	26	MCLKn	31	RX0n
30	RX0p	27	MCLKp	30	RX0p

8	3.3V_GND			3.3V Module Supply Voltage Return Ground,can be separate or tied together with Signal
9	VND_IO_A	I/O		Module Vendor I/O. Do Not Connect
10	VND_IO_B	I/O		Module Vendor I/O. Do Not Connect
11	TX_DIS(PRG_CNTL1)	I	LVC MOS w/PUR	Transmitter Disable for all lanes, "1" or NC=transmitter disabled,"0"=transmitter enabled (Optionally configurable as Programmable Control1 after Reset)
12	RX_LOS(PRG_ALRM1)	O	LVC MOS	Receiver Loss of Optical Signal, "1": low optical signal, "0": normal condition (Optionally configurable as Programmable Alarm1 after Reset)
13	GLB_ALRMn	O	LVC MOS	Global Alarm. "0": alarm condition in any MDIO Alarm register, "1": no alarm condition, Open Drain, Pull Up Resistor on Host
14	MOD_LOPWR	I	LVC MOS w/ PUR	Module Low Power Mode. "1" or NC: module in low power (safe) mode, "0": power-on enabled

30	RX0p	O	CML	Output Data
31	RX0n	O	CML	Inverted Output Data
32	GND			
33	RX1p	O	CML	Output Data
34	RX1n	O	CML	Inverted Output Data
35	GND			
36	RX2p	O	CML	Output Data
37	RX2n	O	CML	Inverted Output Data
38	GND			
39	RX3p	O	CML	Output Data
40	RX3n	O	CML	Inverted Output Data
41	GND			
42	REFCLKp	In	CML	Reference Input Clock
43	REFCLKn	In	CML	Reference Inverted Input Clock
44	GND			
45	TX0p	In	CML	Input Data
46	TX0n	In	CML	Inverted Input Data
47	GND			
48	TX1p	In	CML	Input Data
49	TX1n	In	CML	Inverted Input Data
50	GND			
51	TX2p	In	CML	Input Data
52	TX2n	In	CML	Inverted Input Data
53	GND			
54	TX3p	In	CML	

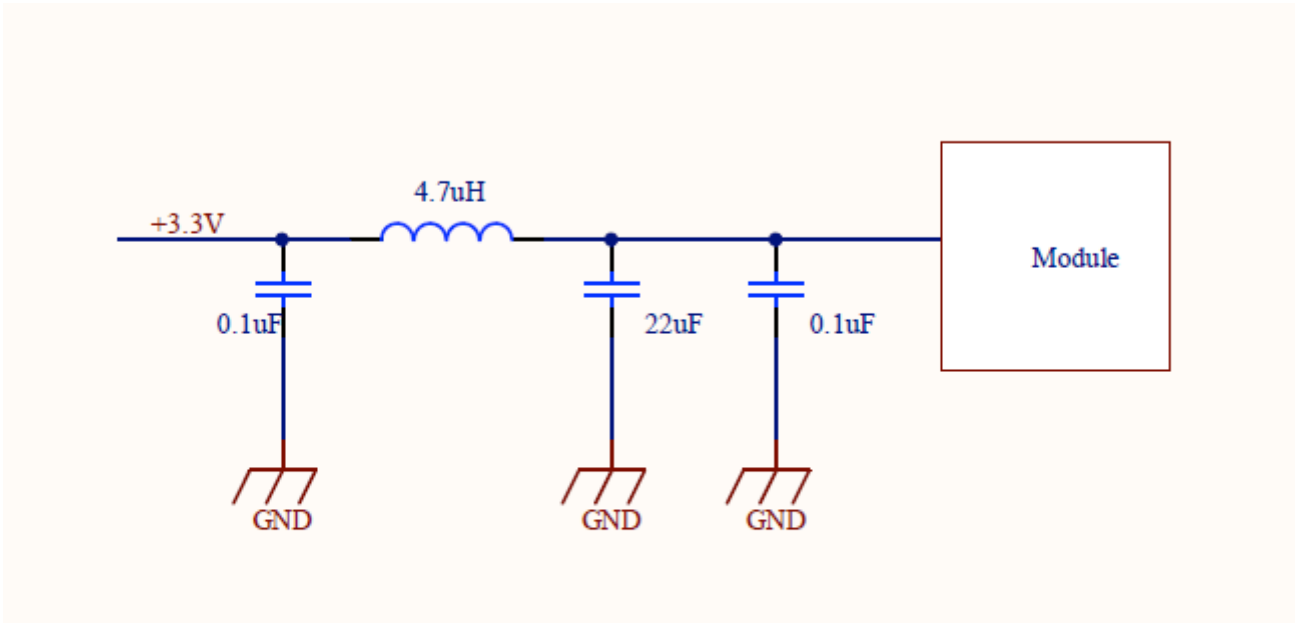
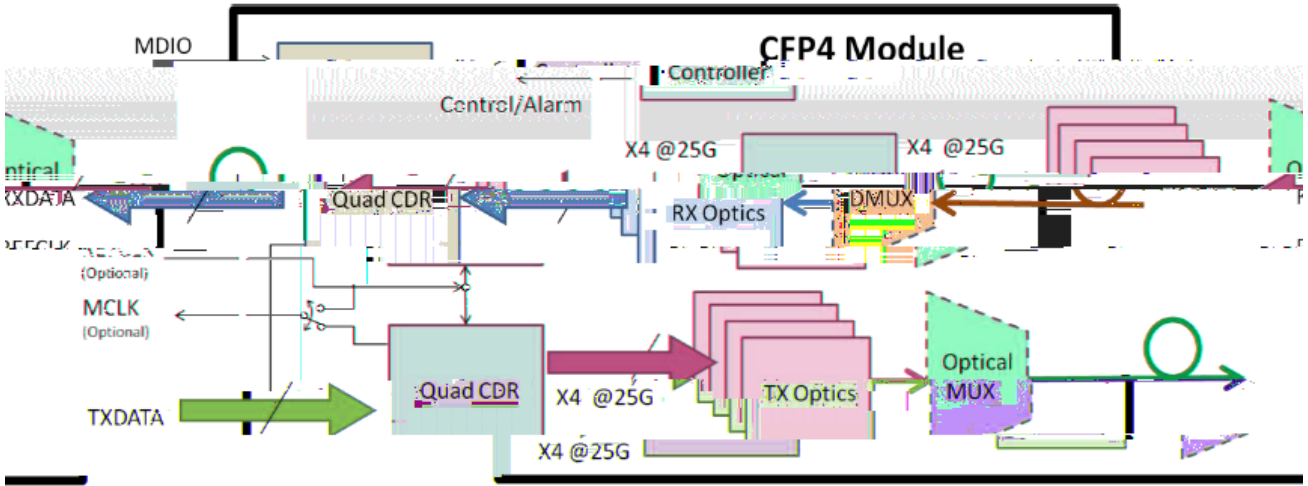

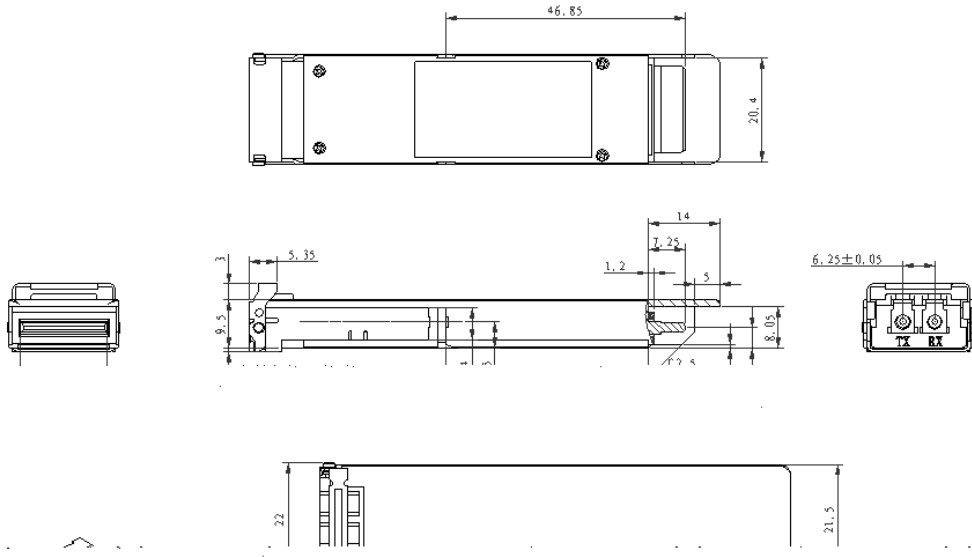

Electrostatic Discharge (ESD) to the Electrical Pins	MIL-STD-883E Method 3015.7	high speed signal pins shall withstand 500V electrostatic discharge based on Human Body Model per JEDEC JESD22-A114-B the other pins with exception of the high speed signal pins shall withstand 2kV electrostatic discharge based on Human Body Model per JEDEC JESD22-A114-B
Electrostatic Discharge (ESD) Immunity	IEC61000-4-2 Class B	15kV air discharges during operation and 8kV direct contact discharge
Electromagnetic Interference (EMI)	CISPR22 ITE Class B FCC Class B CENELEC EN55022 VCCI Class 1	Compliant with standard
Immunity	IEC61000-4-3 Class 2	Compliant with any electro-magnetic regulations
Safety	FDA	

CDRH 21-CFR 1040 Class 1

UL

TUV-GS

CE

Pack	Data rate	Tx	Pout	Rx	S	Top	Reach	Others
RTXM290-701 CFP4	103.125/111.8 Gbps	1310nm LAN Cooled EMA DFB-LD	-2.5~+2.9 dBm	PIN <-8.6dBm	0~70°C	10km	DDM	100GbE/OTU4